

SURFACE MEASURE

PRE1376



Laser scanner for efficient point cloud inspections

Mitutoyo

Highly Accurate, High-Speed, and Highly Efficient
Measurements



SurfaceMeasure

Mitutoyo



With a conventional laser probe, laser intensity and camera sensitivity must be adjusted according to the environment and the workpiece material. In contrast, the **SurfaceMeasure 606**, which automatically adjusts these factors, enables simpler and more comfortable laser scanning.

Introducing the new non-contact line laser probe

The SurfaceMeasure makes it possible to use coordinate measuring machines, until now used primarily as inspection systems, as production systems that can be used throughout the entire process, from development and prototyping to production.

In the development phase

Optimized design utilizing measurement point cloud data significantly improves the efficiency of the development process, even when no master model or CAD data is available for a product.

In the prototyping phase

Shortens the entire process from prototyping to mass production because it can be used simultaneously to compare prototypes with CAD data, check for parts interference and set clearances, and optimize machining settings.

In the production phase

Allows the obtained data to be used for correcting dies, for example, by controlling the variability in mass-produced products, and feeding analysis data back to the preceding process step.

Specification

- Working distance: 93 mm
- Max. scan width: 60 mm
- Measuring range: 60 mm
- Scanning error: 12 μm [1σ /sphere fit]
[Target: Specific reference ball ($\varnothing 30$ mm)]
(According to Mitutoyo's acceptance procedure)
- Resolution: ≥ 0.06 mm
- Max. Acquisition rate: 75.000 points/sec
1.000 points/line
75 Hz
- Laser Class: Class 2 [EN/IEC60825-1(2007)]
- Mass: 430 g
- Dimensions (Unit: mm)

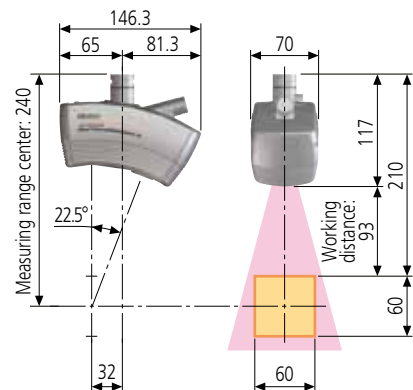

Non-Contact Line Laser Probe Made by Mitutoyo

Powder-sprayless measurement and high-speed scanning

The SurfaceMeasure is a lightweight, high-performance, non-contact, line laser probe developed for use with CNC coordinate measuring machines. The use of digital signals has eliminated the effects of signal deterioration on measurement accuracy and also improved measuring speed.

Furthermore, by automatically adjusting the laser intensity and camera sensitivity according to the environment and the workpiece material, the SurfaceMeasure has achieved powder-sprayless measurement, providing a simpler and more comfortable laser scanning environment.

High-speed scanning

- Positioning control in a maximum of 720 directions enables high-speed scanning of even complex workpieces in the optimum orientation. Additionally, the use of ACR3* allows you to make fully automated measurements while selecting "non-contact" and "contact" probes as desired.
- Using the ACR3 equipped with a power supply port for the laser probe, which can be specially ordered, eliminates the need for warming up the laser probe.



*ACR3 is a trademark of Renishaw plc.

- The SurfaceMeasure, with a measuring area of 60 mm (W) x 60 mm (D), captures data at the rate of 75 lines/sec.

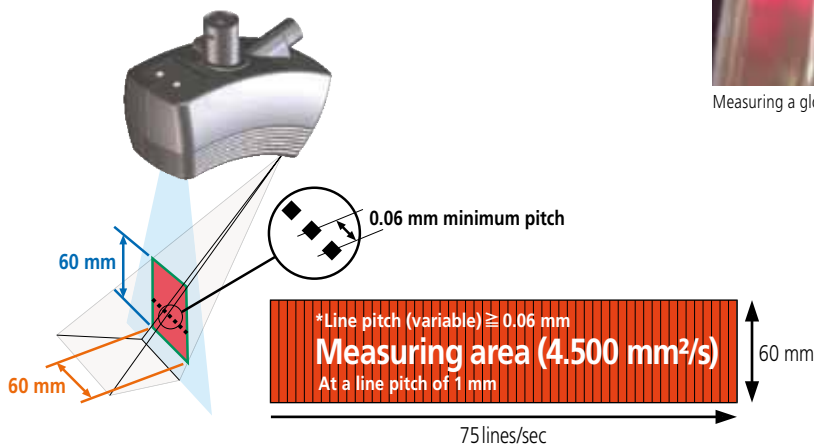

Powder-sprayless measurement

- Since the laser intensity and camera sensitivity are automatically adjusted, stable shape data can be obtained even when the workpiece has multiple colors and varying degrees of reflectance.



Measuring a colorsample plate

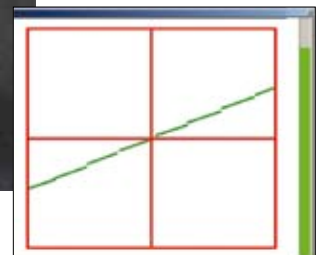

Measuring a glossy object

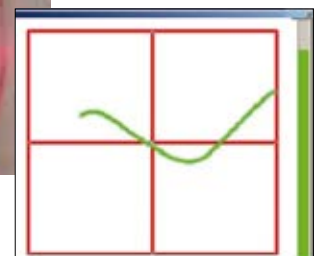

Off-Line Teaching Software to Improve Work Efficiency

Off-line teaching: MSURF-G

Since MSURF-G can use model data to create measurement macros, measurement operations can start immediately when the actual object is ready. MSURF-G increases the availability factor of measuring machines and, when combined with MSURF-I, significantly reduces the number of process steps in everything from measurement to product evaluation.

- Reduces the time the CMM was previously occupied in the creation of measurement macros.
- Allows easy creation of measurement macros, regardless of the skill level of the operator.
- Optimizes workflow from measurement to evaluation.

- Semi-automatic function for creating measurement paths with optimum probe orientation
 - To create a measurement path, simply specify a single point on the model.
 - The optimum scanner orientation is automatically selected.
 - This function creates new measurement paths while avoiding areas where measurement paths have already been created.

*On sheet metal, the semiautomatic function can be used on approximately 95% of the entire area.

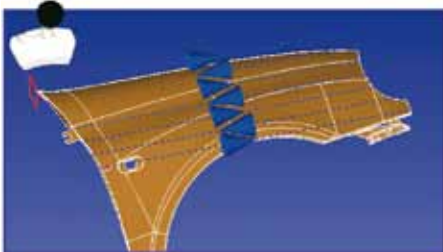

- Generation of simulated data for the point cloud data expected to be obtained through scanning
 - Creates point cloud data on work models while adjusting for the measurement conditions (scanner orientation, measurement pitch, overlap, etc.), the camera's blind spots (the laser projection direction and the position of the model), and the scanner conditions (effective field of view, reflection angle, etc.).

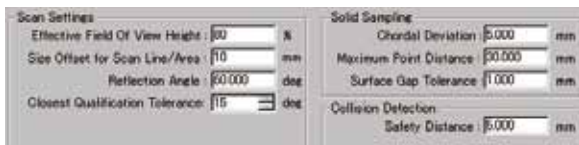

- Displaying measurement movements (scanner movements) in animation
 - Replays the measurement movements at an appropriate speed by adjusting for the type of scanner being used and the stripe pitch.

- A slider can be used to adjust the speed at which the scanner movements are displayed. The animation can also be advanced or reversed.

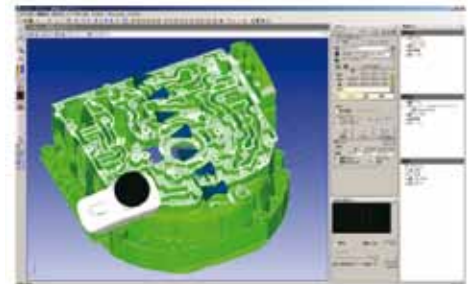

- Detection of collision between the "laser probe + probe head" and the model
 - When a collision is detected, the collision area is displayed in red and the collision information is output in an inspection tree.

*Collision with the spindle cannot be detected.



Output of scan information containing a detected collision.

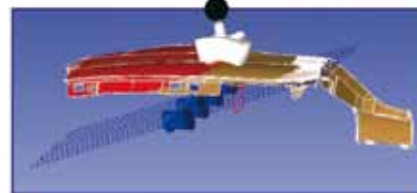
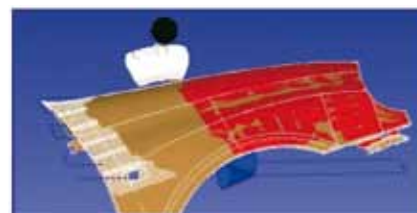

When a collision is detected, the area is displayed in red.

- When a measurement macro is created, the macro execution time is estimated. This time is calculated from the measurement conditions and the coordinate measuring machine used, resulting in a value close to the actual time.

Macro time: 00:04:51



Providing Measurement Solutions with Non-Contact Line Laser Probes to Strengthen Manufacturing Capability

User-friendly point cloud data processing software

Evaluation based on non-contact measurement begins with the process of accurately capturing the surfaces of the product that has been formed. The high density point cloud data obtained from the surface of a part is utilized by evaluation software programs for data analysis purposes, such as extraction of geometric elements, evaluation of free-form surfaces and profile shapes, and comparison with master data. Furthermore, utilizing the obtained data in reverse engineering can revitalize the creative and manufacturing cycle that uses 3D data as its core.

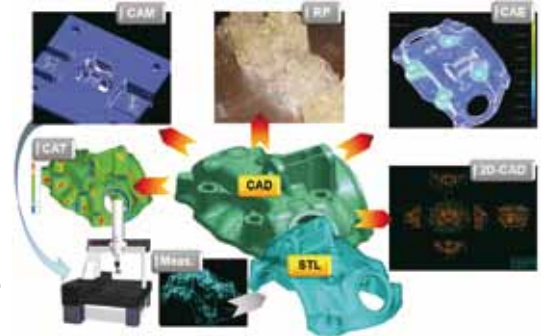

Scanning: MSURF-S

- Scanning paths can be created by simply defining three items: the scanning starting point, the scanning length, and the scanning width.
 - You can easily define these three items using the joystick while checking the camera preview.
 - If point cloud data or master data is displayed on the screen, you can define the three items using the mouse on the data. This feature is convenient for creating a measurement path based on simulation and for specifying areas where data needs to be re-measured, both of which are useful in reducing the number of measurement steps. These operations can be easily carried out using the joystick.



- Scanning paths can be registered as measurement macros.
 - You can use the override function to modify all or some of the measurement conditions in the created measurement macros.
 - The submacro function is effective for measuring multiple units of the same workpiece.
 - The execution time of a measurement macro is computed from the measurement conditions and the coordinate measuring machine specifications.



- Point cloud data obtained from scanning can be exported in text or STL format.
 - These data can also be processed using various kinds of software programs designed for processing point cloud data.
- MSURF-S can be started from MCOSMOS
 - Since a work coordinate system created in MCOSMOS can be utilized by MSURF-S, you can execute fully automatic measurements that merge "contact" and "non-contact" measurements.

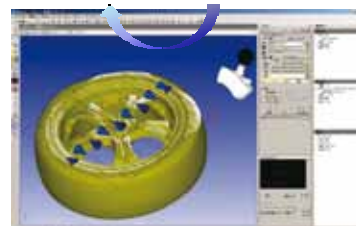
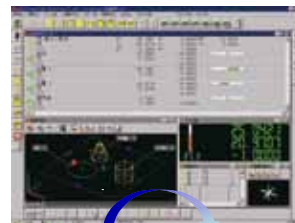

Note: If ACR3 is not used, the probe must be manually changed.

Inspection: MSURF-I

■ Importing CAD data

- Support of IGES, STL, and SAT formats is standard.
- Optional formats available include CATIA V4, CATIA Variable, ProEngineer, Unigraphics, STEP, and VDAFS.

■ Feature-by-feature comparison

- You can detect various features from point cloud data or mesh data and compare them to the design data. From features containing point data, such as a circle, you can calculate the dimensions between the features.
- Features that can be detected include the basic elements such as planes, points, straight lines, slots, cylinders, circular cones and spheres as well as welded bolts, welded nuts, cylindrical pins, T-studs, etc.

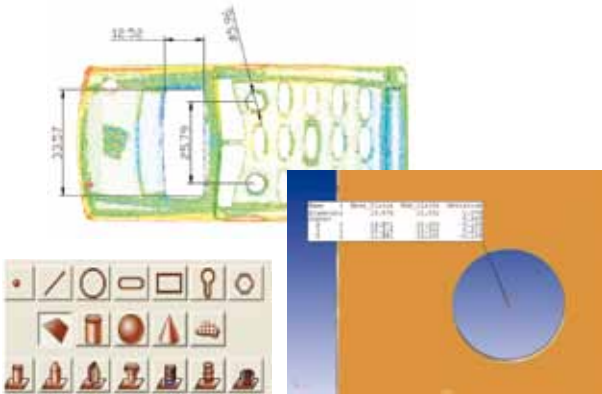

■ Comparison of cross-sectional shapes

- You can cut point cloud data or mesh data to compare cross-sectional shapes or compute angles, distances, radii, etc.
- Additionally, the optional turbine blade analysis function can compute the LE thickness, TE thickness, maximum thickness, chord length, etc.

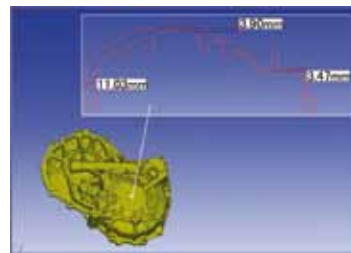

Cross-sectional evaluation (dimension computation)

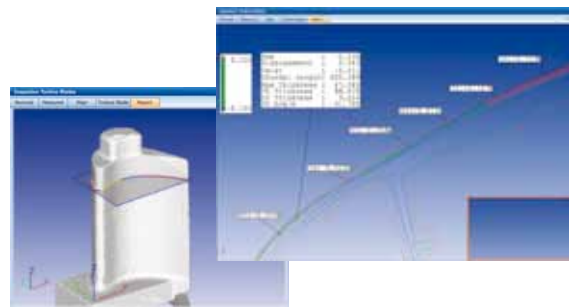

Turbine blade analysis (optional function)

■ Planar shape comparison

- Point cloud data or mesh data can be compared with CAD data, and the planar shape errors displayed on a color map.
- Since wall thicknesses can be displayed on a color map, there is no need to cut the workpiece as is necessary with conventional methods.
- A simulated digital caliper function enables quick evaluation of a wide variety of steps and gaps.
- When evaluating the curvature of a surface, the angle R within the specified tolerance, for example, can be evaluated.

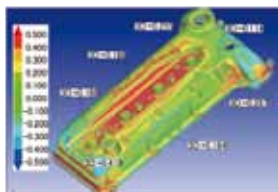

Color map of errors

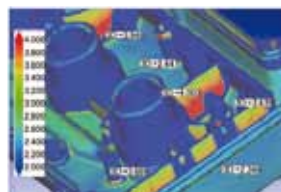

Color map of wall thickness

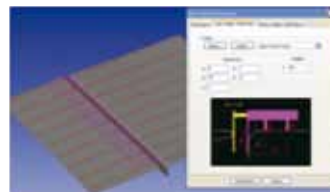

Evaluation of steps and gaps

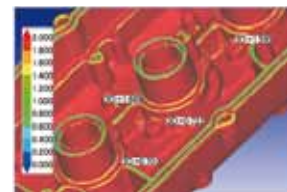

Evaluation of surface curvature

■ Creation of an operating procedure macro using the automation function

- The automation function can record the operating procedure, including the execution of measurement macros. This function allows you to automate a series of operations, from measurement, to evaluation, to report creation.

When you purchase Coordinate Measuring Machines from Mitutoyo, you are drawing on the outstanding experience and expertise of the world's leading specialist in production measurement technology. You will also be drawing on decades of knowledge for the tasks of tomorrow. Setting the highest standards for quality, performance and progressive technology.



**Ask for our general brochure
"Coordinate measuring machines".**

It provides you with a compact overview of the wide diversity offered by nextgeneration CMM technology developed by Mitutoyo.

Further information can be found in our product lounge
Coordinate measuring machines:
www.mitutoyo-produkte.de

Coordinate Measuring Machines	1
Vision Measuring Systems	2
Form Measurement	3
Optical Measuring	4
Sensor Systems	5
Test Equipment and Seismometers	6
Digital Scale and DRO Systems	7
Small Tool Instruments and Data Management	8

Mitutoyo Europe GmbH
Borsigstraße 8-10
41469 Neuss
T +49 (0)2137-102-0
F +49 (0)2137- 351
info@mitutoyo.eu
www.mitutoyo.eu

Note: All information about our products in this printed material, particularly the illustrations, drawings, measurement and performance specifications, as well as other technical specifications are to be interpreted as approximate average values. In this respect, changes in construction, technical specification, measures and weights remain reserved. Our specified standards, similar technical regulations as well as the technical specifications, descriptions and illustrations of products are accurate on the date of printing. Furthermore, our general terms of business in the currently applicable revision are binding. Only the offers we make are definitive.

Mitutoyo